

COMPACT

STRAIGHT EDGE POLISHING MACHINE

MACHINE'S
BACK SIDE

VISTA TRASERA
DE LA MAQUINA

zomato
USA

COMPACT

STRAIGHT EDGE POLISHING MACHINE

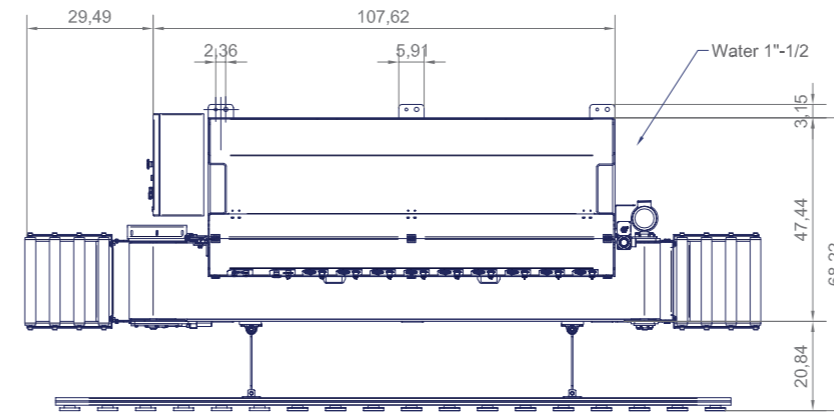
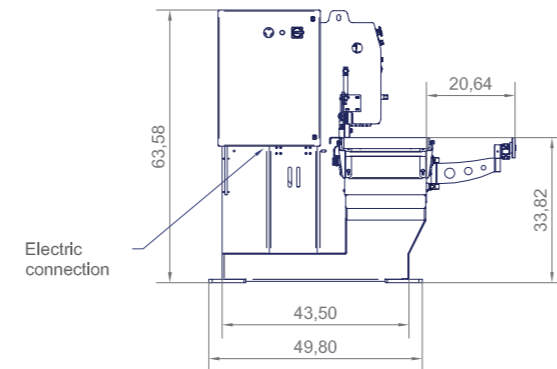
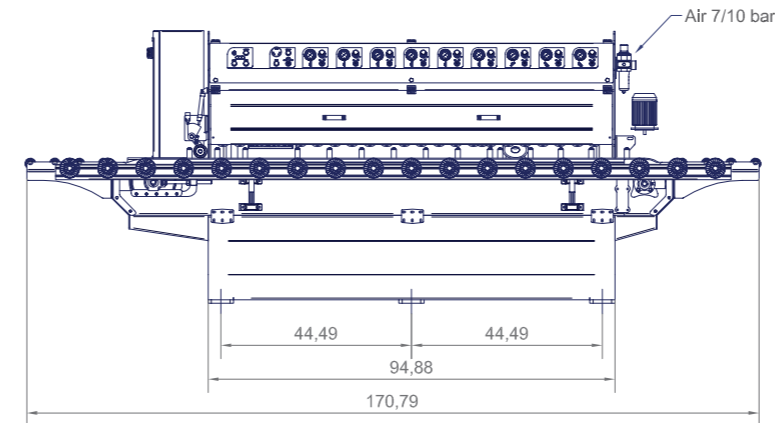

- 7 polishing units
- 2 upper bevelling units
- Lower bevelling unit
- Multi cutting 0/90° unit

Automatic belt edge-polishing machine for polishing edges of marble, granite, agglomerates and ceramic material with thickness from 1 to 6 cm.
The COMPACT machine is peculiar for the reduced dimensions, its high quality and easy to use, that make this machine suitable for any field, from building and funerary materials to furniture.
It's available in three different versions to meet any needs.
The machine is made up of 7 units for polishing edges and 2 units for working bevells.
Multi-cutting groups with 0/90° rotation for tilted cuts, upper groove, sizing, etc. Thanks to the pneumatic pressure rollers it is possible to work at the same time pieces having different thickness.

MAIN FEATURES:

The machine has a rugged monolithic electro-welded structure that is worked with a machine tool, hand-blasted and painted with kiln drying, that is a guarantee of max solidity and resistance towards foreign agents.
The belt shifting surface is covered with interchangeable rust-preventing stainless steel. Belt with guides. Automatic management of the spindle working cycle and pneumatic pressure rollers.
Electronic adjustment of the belt speed. Water collecting tank with conveyed outlets. Material supporting inlet and outlet beds of rollers. Supporting bar for projecting pieces. The main cases are in stainless steel or aluminium. The machine is equipped with all safety mechanic and electric protection devices according with EEC European standards, with the visible "CE mark".

- Unidades abrillantadoras 7
- 2x bisel superior
- Bisel inferior
- Multicorte 0/90°

Pulecantes automática con cinta para pulir cantos de mármol, granito, aglomeraciones y cerámicas desde 1 a 6 cm de grosor.
El pulecantes COMPACT se caracteriza por sus dimensiones reducidas, su alta calidad y su simplicidad de uso, la convierten en la máquina ideal para cualquier sector, desde la construcción a la funeraria o a la decoración. Disponible en tres versiones para satisfacer todas las exigencias.

Formada por:

7 unidades para el pulido de cantos, unidad para el biselado.
Grupo multicorte con rotación 0/90° para la ejecución de cortes inclinados, goteo, calibrado, etc. Gracias a los compresores neumáticos es posible trabajar trozos de distinto grosor al mismo tiempo.

CARACTERÍSTICAS PRINCIPALES:

Máquina compuesta por una robusta estructura monolítica, electrosoldada, trabajada con una máquina herramienta, enarenada barnizada y secada en horno, garantía de máxima solidez y resistente a agentes externos. Pista de desplazamiento de la cinta recubierta de acero inoxidable antidesgaste e intercambiable. Cinta dotada de guía. Gestión automática del ciclo de trabajo de los mandriles. Compresor neumático con gestión automática. Ajuste eléctrico de la velocidad de la cinta. Bañera de recogida del agua con deshechos canalizados. Rodillo de soporte del material en entrada y en salida. Barra de soporte para piezas protuberantes. Cáter principal en acero inoxidable o aluminio. La máquina está dotada de todas las protecciones.

zomato
USA

ZONATO USA Corp.

Legal Unit Address:

94 Sunset Ave. - Selden NY11784

Phone: +1 (631) 236-6528

E-mail: zonatousa@gmail.com - zonato@zonato.eu





MULTIFUNCTION SPINDLES
Grupo multicorte con rotación 0/90



CHAMFERING SPINDLES
Unidades para el biselado



INDIPENDENT VERTICAL PRESSORS
Pressores neumático independientes

COMPACT

STRAIGHT EDGE POLISHING MACHINE



Calibrating
Calibración

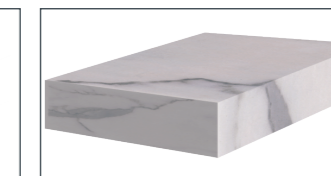

Flat Edge Polishing
Pulido de bordes rectos

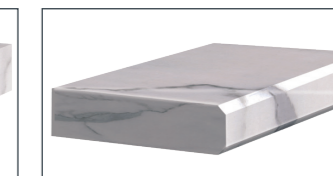

Chamfering
Bisel

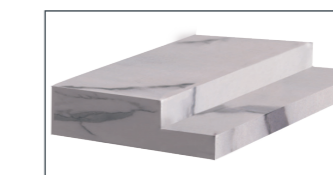

Slot
Bajo relieve

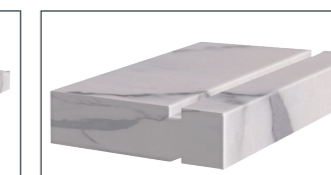

Water drip
Goteo de agua

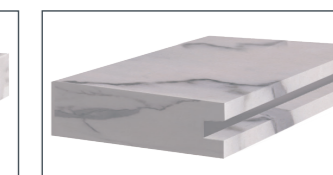

Kerf edge
Kerf

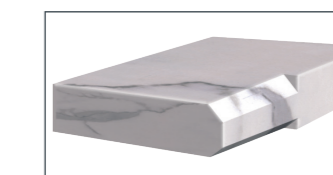

Raw profiling
Perfil en bruto

